



GPS1201 GPL-GPS Receiver Data Sheet

The GPS Creations GPS1201 board is designed to support the Open Source GPL-GPS software development effort. The GPS1201 board contains a receiver serial port output to PCI bus design making it easy to use the GPS receiver board in most modern PC's that have Windows or Linux operating systems. It can even be used on older systems using DOS provided a "Xmodem" program or similar is used to load the GPL-GPS code into the GPS receiver. The GPS1201 board is shown in figures 1 & 2. Please refer to the major components noted.

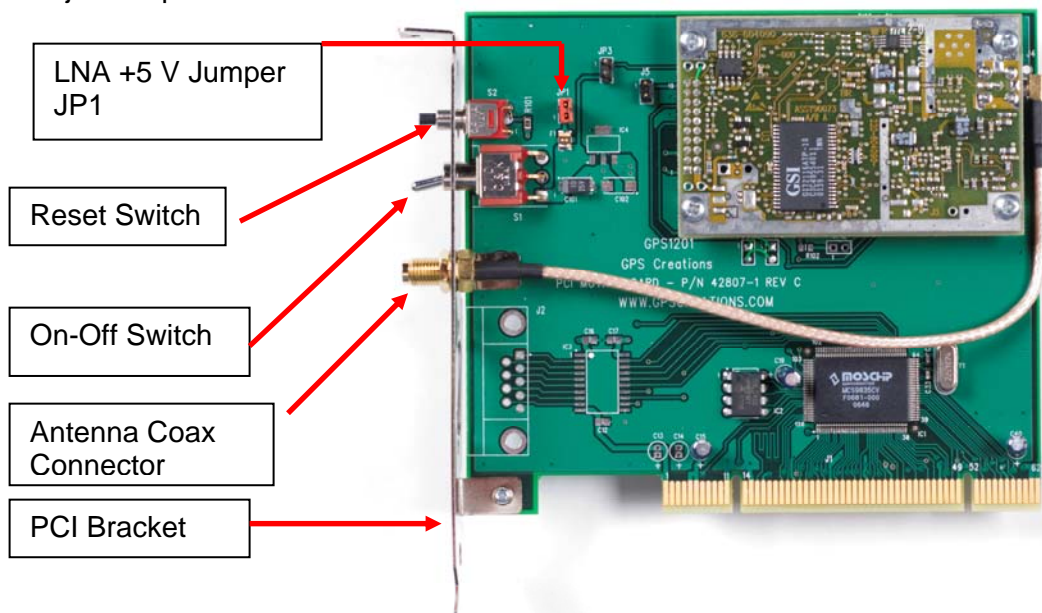

Figure 1 – **GPS1201** Board Including Novatel Modified GPS Receiver For GPL-GPS Applications

Figure 1 shows the location of the user interface parts of the GPS1201 located on the rear mounting bracket. Note the location of JP1 which must be installed if the GPS antenna to be used with the GPS1201 requires +5 volts to feed the LNA circuit in the antenna. Remove JP1 if the antenna to be used is passive or does not require a voltage feed. The GPS antenna system to be used with the GPS1201 should have between 10 to 26 dB of gain.

Figure 2 shows the Novatel Superstar II GPS receiver board and the MosChip 9835 PCI bus interface device. The Superstar II receiver has been modified to permit erase/rewrite control of the flash memory and the standard RAM IC has been removed and a larger one installed permitting more storage space for the GPL-GPS code. The

GPS1201 board has a layout which permits installing several different GPS receivers. But the Novatel Superstar II is the only one which currently can be used with the GPL-GPS open source code.

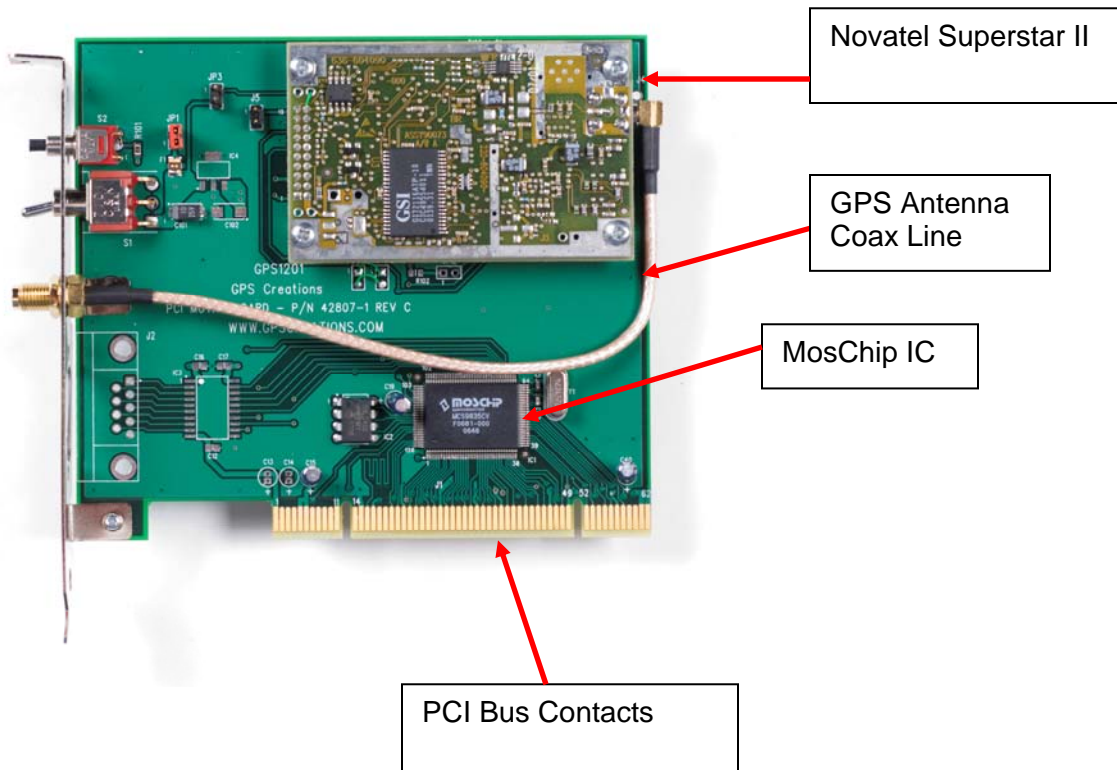
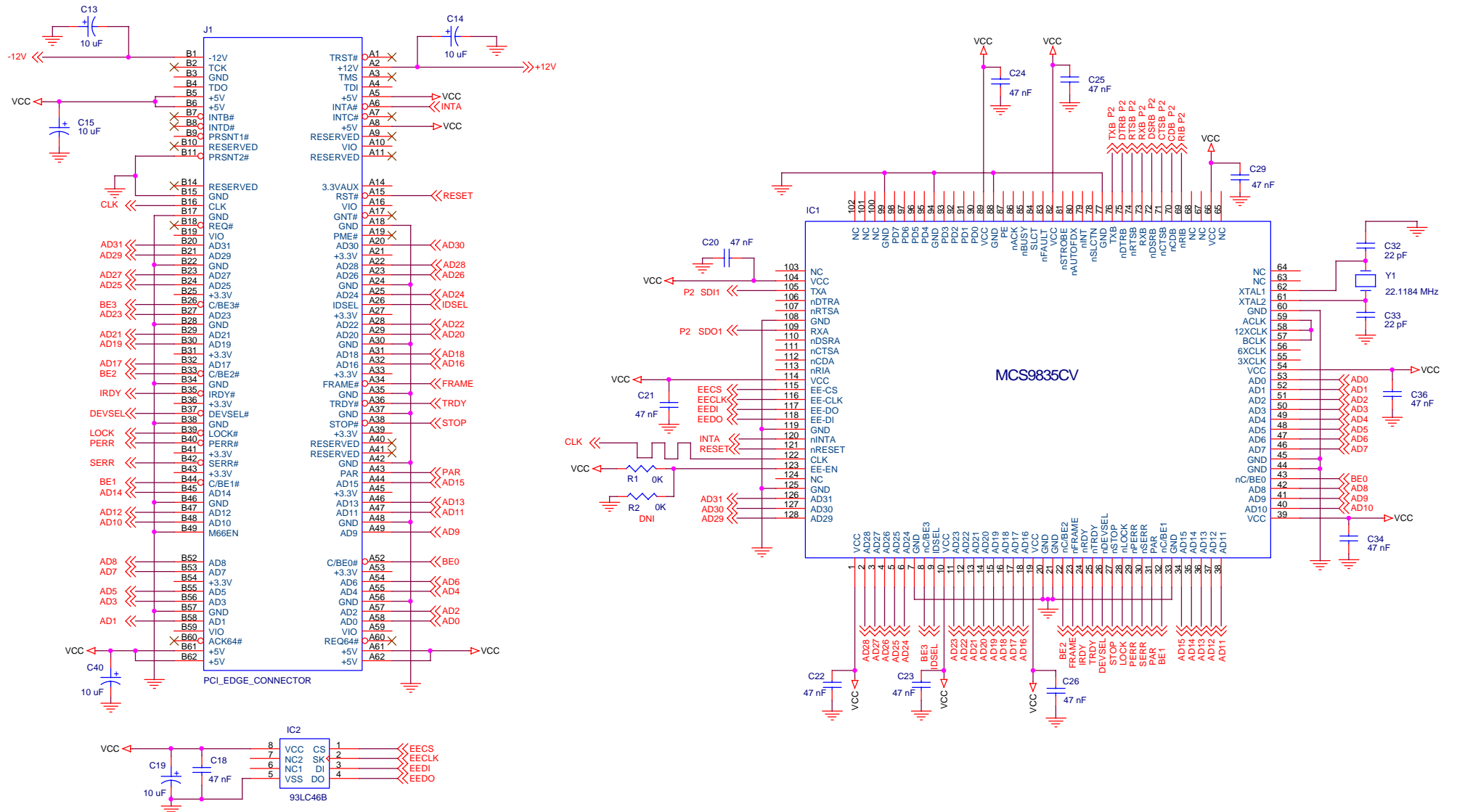

Figure 2 - **GPS1201** Board Including Novatel Modified GPS Receiver For GPL-GPS Applications

The schematic diagram shown on pages 3 & 4 also shows how different GPS receivers can be installed on the mother board. But only the components shown in the block with J3 (the 20 pin connector) are installed on the GPL-GPS version. Since both com ports from the GPS receiver are connected up to go through the PCI bus of the computer, the cmos to RS232 converter IC (IC3) and the associated DB-9 connector are not installed on the GPL-GPS version board.

Page 3 contains the circuit of the MosChip (IC1) and associated components necessary for interfacing to the computers' PCI bus. IC2 is the E²PROM which contains data that identifies the MosChip as a serial I/O device. IC2 is pre-programmed by GPS Creations and permanently soldered to the GPS1201 board. It should not be necessary to modify the data stored in IC2. Contact GPS Creations if it is necessary for whatever reason to get the program data for IC2.



GPS CREATIONS		
Title		
GPS1201		
Size	Document Number	Rev
B	42807-1	C
Date:	Sunday, September 09, 2007	Sheet 1 of 2

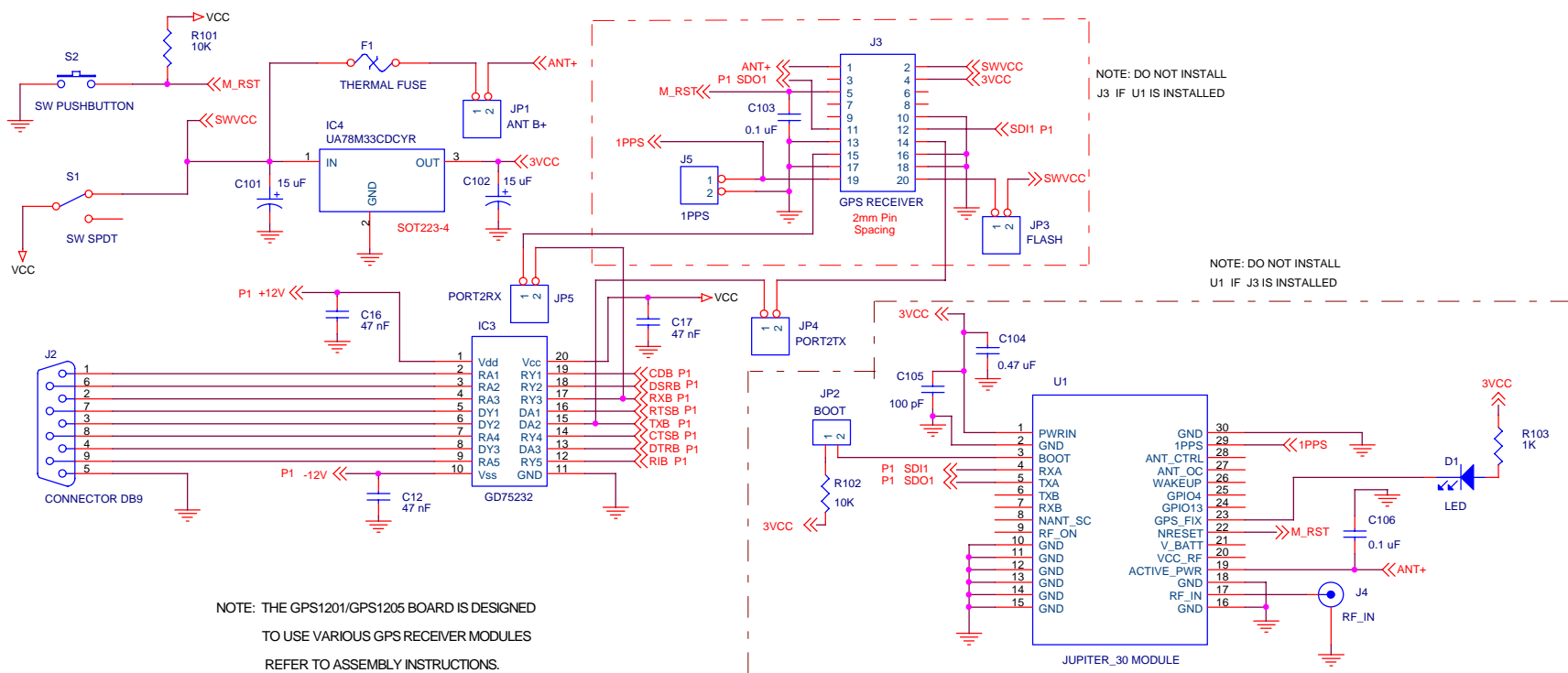

NOTE: THE GPS1201/GPS1205 BOARD IS DESIGNED TO USE VARIOUS GPS RECEIVER MODULES REFER TO ASSEMBLY INSTRUCTIONS.

GPS CREATIONS		
Title	GPS1201	
Size B	Document Number	Rev C
	42807-1	
Date:	Tuesday, September 11, 2007	Sheet 2 of 2

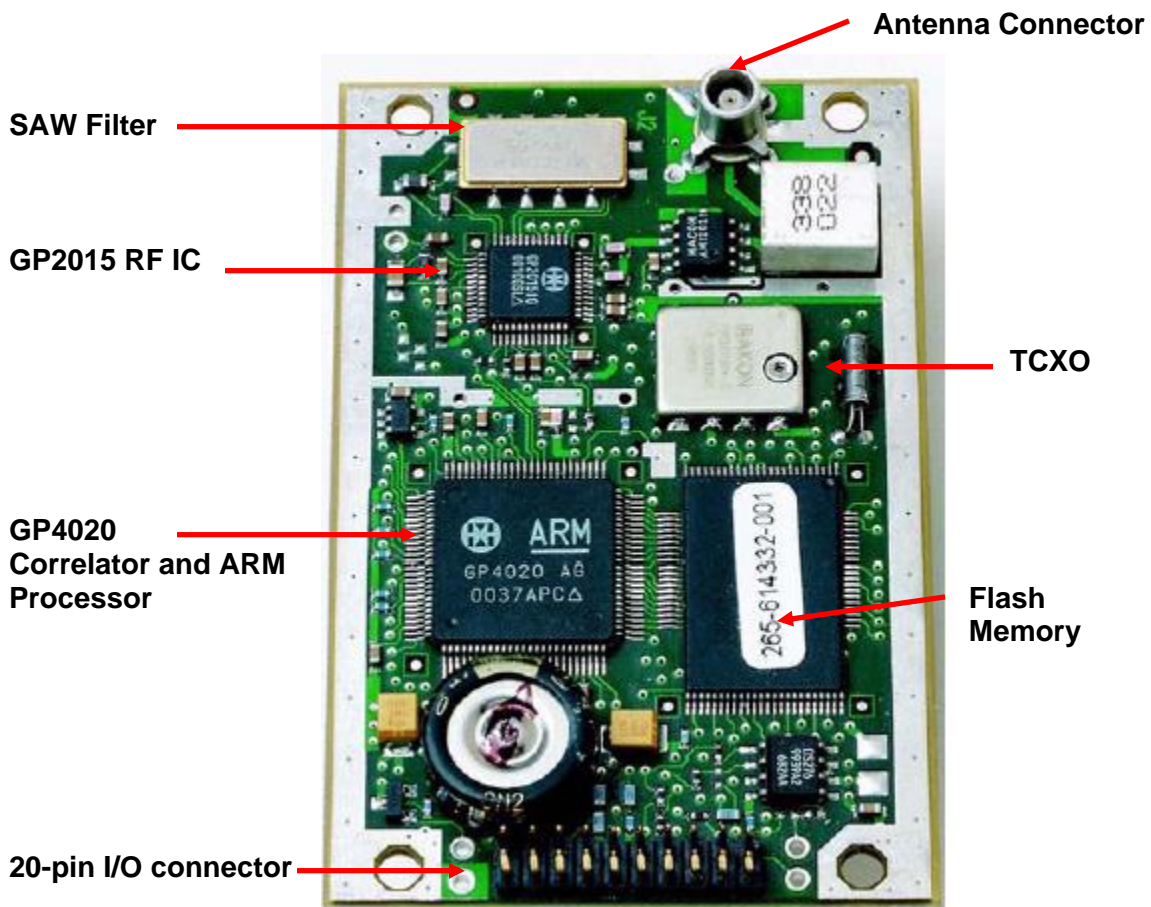

Figure 3 – Component Side of the Novatel Superstar II Board

The Novatel Superstar II GPS receiver documentation is included in the “related documents” folder in the CD supplied with the GPS1201. Please refer to that folder for detailed information on this part.

The modified larger RAM IC has been installed on the solder side of the Superstar II board. It is a GSI Technology GS72116ATP, 128K x 16 Mb part. The datasheet on this part is also included in the GPS1201 “related documents” folder.

The Superstar II board plugs into the GPS1201 motherboard using the 20-pin connector and held in place at the four corners of the board with machine screws. This provides easy removal of the GPS receiver board should one need to gain access to the parts installed underneath the receiver on the motherboard.

As mentioned on the GPS1201 brochure and other documents, the flash memory on the Superstar II board has already been factory loaded with the **RedBoot** operating system. Documentation on **RedBoot** is also included on the GPS1201 CD. To access the RedBoot OS, use the serial interface for UART # 1 (Com port 3).

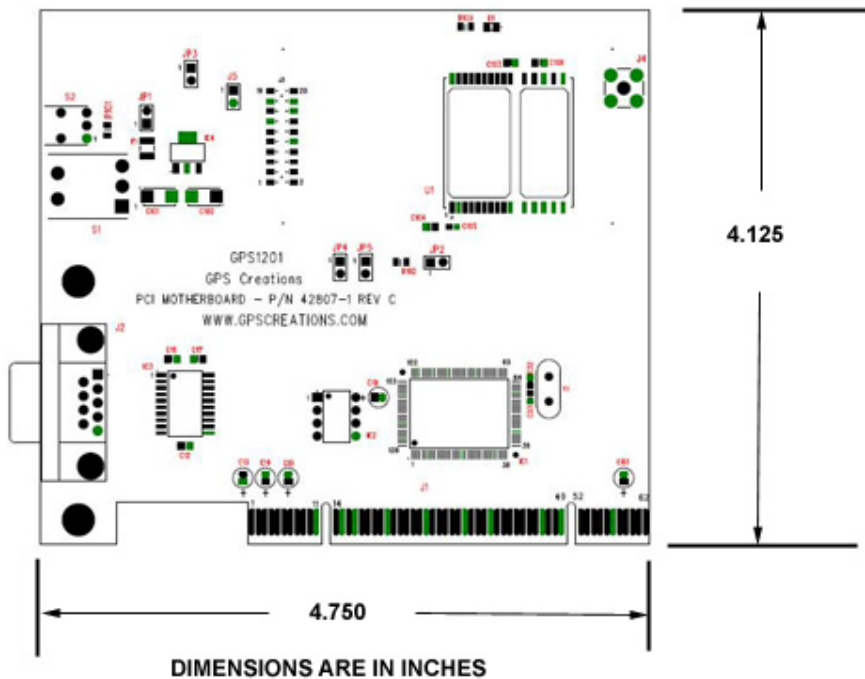

Figure 4 - Dimensions of the GPS1201 PCI board.

The user is requested to consult the GPS1201 Installation and Operation document for additional information on use of the GPS1201 board.

GPS Creations is not responsible for operation of the receiver if the user does not install the board correctly in the computer or properly install the software or operate the hardware in a manner in which it was intended. Also, correct operation of the receiver can only be obtained by having a properly designed GPS antenna installation. Information provided by GPS Creations is believed to be accurate and reliable. However, no responsibility is assumed by GPS Creations for its use, nor any infringement of patents, or other rights of third parties, which may result from its use. No license is granted by implication or otherwise under any patent rights of GPS Creations other than for circuitry embodied in GPS Creations products. GPS Creations reserves the right to change circuitry at any time without notice. This document is subject to change without notice.